

Druckanschluss P Schmiermittel  
G1/8" (AGR)  
Pressure connection P lubricant  
1/8" BSP (AGR)

Druckausgang A fuer Dosiernadel  
Pressure output A  
metering needles

Pneum. Anschluss 2 und 4  
Pneumatic connection 2 and 4  
ø 4/2 mm

<p>Langackerstrasse 25 CH-6330 Cham www.abnox.com</p>	Hauptabmessung : 137 x 46 x 23 mm			Art. - Nr. : 4191800	
	Gez.: 18.02.10	Visum: LI	Index: A	Version: 3	Aenderung:
Benennung: Microdosierventil Micro metering valve			Blatt Nr.: 1		Anzahl Bl.: 2
Modell: 000-00737-ASSEM A-5			Z.-Format: A2		Masstab: 2:1
Urspr.: -			Zustand: Freigegeben		Zeichnungsnummer: M000-00737

- Magnetfeldsensor fuer C-Nut  
 - Magnetic field sensor for c-nut  
 Art.-Nr. 0001220  
 1:1

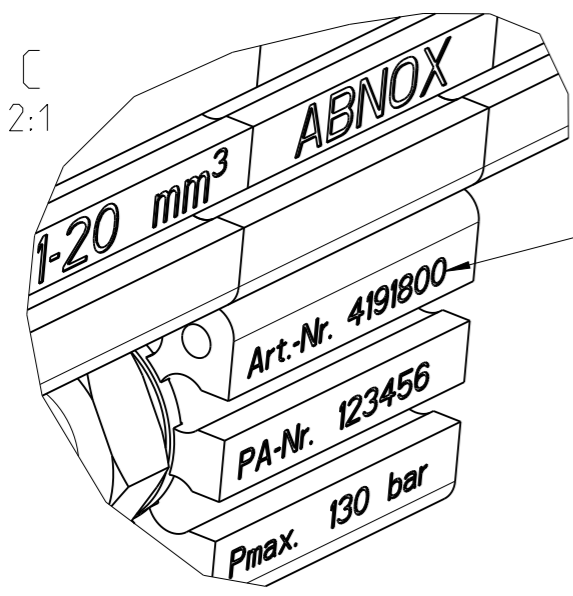
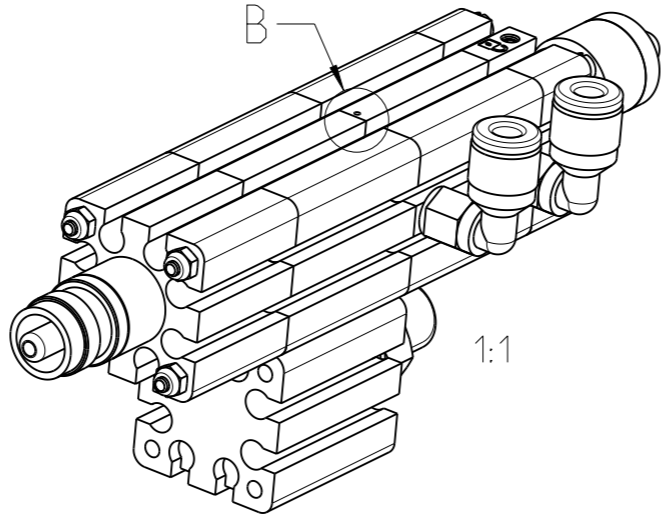
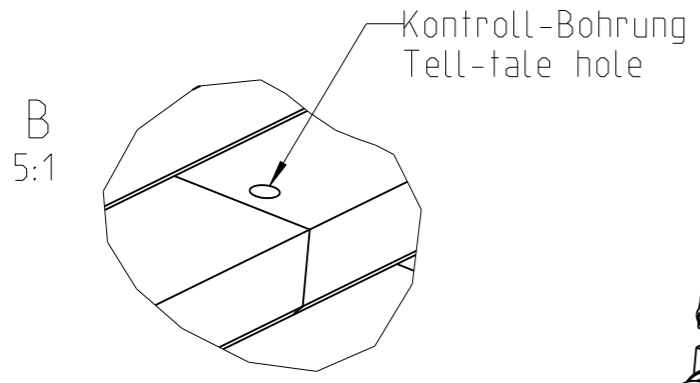
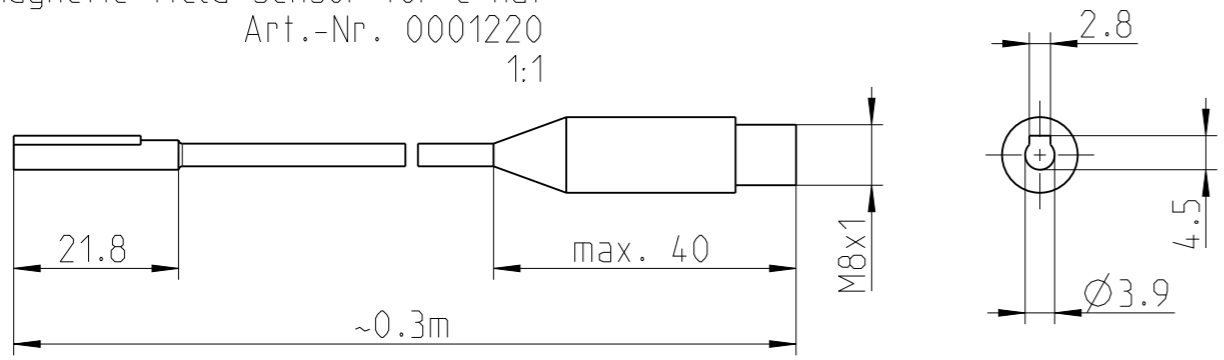

Kennzeichnung  
 Labelling

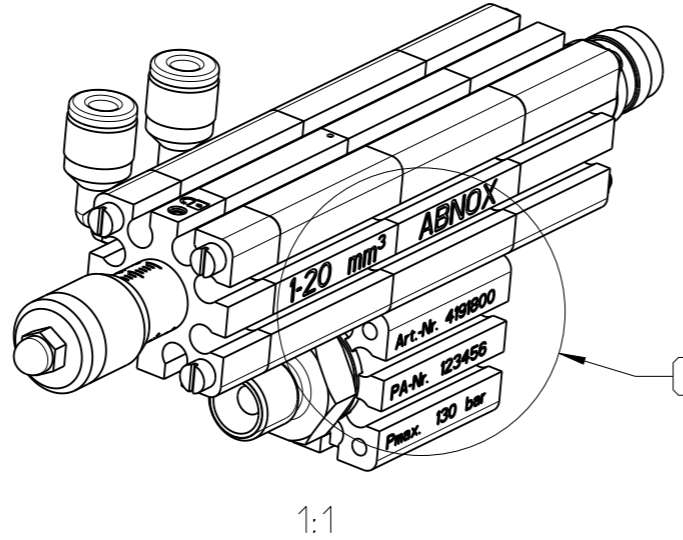

Modell Model	Montageblock Support bracket
Bauform Construction type	Standard
Ausfuehrung [cm³] Version [cm³]	0.001 - 0.020
Gewicht [kg] Weight [kg]	0.164
Anschluss Innengewinde P Connection internal thread P	G 1/8" 1/8" BSP
Anschluss Innengewinde A Connection internal thread A	M5
Anschluss Innengewinde 2 & 4 / Schlauch Connection internal thread 2 & 4 / Hose	M3 / ø 4/2 mm
Befestigungsgewinde (Nutstein) Fastening thread (nut)	M2.5
Min. / Max. Druck [bar] Min. / Max. pressure [bar]	20 / 130
Druck OUT [bar] Pressure OUT [bar]	40
Min. pneum. Betriebsdruck [bar] Min. operating air pressure [bar]	5.0
Max. pneum. Betriebsdruck [bar] Max. operating air pressure [bar]	7.0
Optimaler pneum. Betriebsdruck [bar] Optimum operating air pressure [bar]	6.0
Dosierbereich [cm³] Dispensing range [cm³]	0.001 - 0.020
Max. Penetration NLGI-Klasse Max. penetration NLGI classification	3
Max. dynamische scheinbare Viskosität [mPas] Max. apparent dynamic viscosity [mPas]	1'000'000
Einsatzmediumspezifikation Specification for operation medium	Bis NLGI 3 max. 1'000'000 mPas Up to NLGI 3 max. 1'000'000 mPas

Hauptabmessung : 137 x 46 x 23 mm		Art. - Nr. : 4191800	
Gez.:	Datum: 18.02.10	Blatt Nr.: 2	Anzahl Bl.: 2
Visum: LI	Index: A	Version: 3	Masstab: 1:1
Aenderung: -		Z.-Format: A3	Zeichnungsnummer: M000-00737
Benennung: Microdosierventil Micro metering valve		Zustand: Freigegeben	
Modell: 000-00737.ASSEM	A-5	Urspr.: -	Ers. f.: -